

Type KC40 Isolation Interlock



SD Series

KIRK Type KC40 interlock, also known as a CN22, is a threaded cylinder interlock that engages directly with the linkage of equipment to isolate power. The key can be assembled to be trapped or released according to the desired position of the cam, as needed for the interlock safety solution. The KC40 is manufactured with no housing and is meant to be installed with provisions or bracketry supplied by the OEM specifically for this interlock. Each KC40 is supplied with two lock nuts for mounting.

OPERATION

KIRK Type KC40 cylinder interlocks are mechanically operated and engages directly with the equipment to isolate power.

Type KC40 isolation interlock

- 1 Key is trapped, linkage is engaged, breaker is closed.

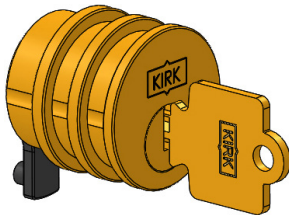

- 2 Open the breaker and turn the key to the released position. This will lock the breaker open

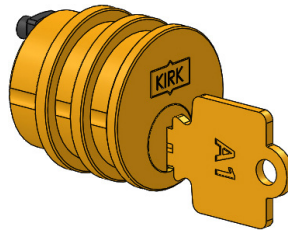

- 3 Key is now released, power is isolated, and key is free to move to the next sequential interlock in the safety process.

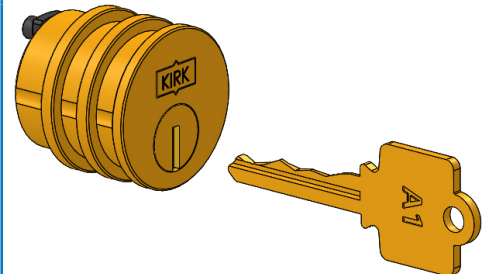

Type KC40 Isolation Interlock



USAGE

KIRK Type KC40 interlocks should be used on equipment as specified by the OEM in which provisions have been provided. KIRK cylinder interlocks ensure that once the linkage on the equipment has been engaged into the desired position as defined by the end user's safety process and following the operations of the interlock, the power is now isolated from changing state until the procedure is reversed.

 KIRK cylinder interlocks are not designed to serve as an access interlock into hazardous areas.

No hazardous substances were used in the manufacturing of the product. The product can be disposed of in standard waste receptacles.

INSTALLATION

The KIRK Type KC40 interlock is recessed mounted using OEM provisions. After installation of the cylinder interlocks, the complete interlock system should be tested sequentially by person(s) familiar with the entire system, the key sequence, and its intended purpose. Any problems or discrepancies must be corrected prior to energization.

SD series (brass) interlocks are supplied with a key in each cylinder. These keys are needed during installation of the interlocks.

 For all interlock systems to maintain system integrity, additional keys must be removed from the system and destroyed or retained by a responsible person. There should only be enough keys to operate the interlock system sequentially. Kirk Key Interlock Company will not be responsible for extra keys left in the interlock system.

 All interlocks and interlock systems must be installed by a competent and qualified person who has read and understood these instructions. Please retain this document in your technical files.

 Before removing the cam, please be sure that the key is removed from the lock. This ensures that the plug does not slide out, releasing all of the drivers and pins of the lock.

MAINTENANCE

Kirk key interlocks should be periodically lubricated with a small amount of dry powder graphite. DO NOT use oil or grease of any type as these will collect dirt and impede the proper operation of the lock cylinder.

SD SERIES: Apply a small amount of graphite to the key and insert the key into the lock cylinder. Work the key in and out and turn the key several times in order to distribute the graphite inside the lock cylinder.

KIRK offers a Graphite Lubrication kit (part# GL-1) complete with instructions for use.

Type KC40 Isolation Interlock



TECHNICAL DATA

Type KC40	SD Series
Cylinder Interlock	Brass
Plug/Inner Turn Shaft	Brass
Key Material	Nickel-Silver
Key Style	7-Pin Tumbler
Type of Mounting	Recess mounted using OEM provisions
Temperature Ratings	-65F to +250F
Weight	.41 pounds

* Weight based on product with no key or mounting hardware

APPLICATION

The Type KC40 cylinder interlocks are used as part of safety systems suitable for the control of circuit breakers.

The interlock application example, scheme 35A from the KIRK scheme book, is to prevent the closing of breaker A when breaker G is closed.

Initial system status: Breaker A is closed to supply load M. Key A-1 is held in the Type KC40 interlock on breaker A. Generator breaker G is locked open and cannot be closed until breaker A is locked open.

To transfer load M to the generator, open breaker A. Turn key A-1 in the Type KC40 mounted on breaker A to lock open and release key A-1. Insert key A-1 into interlock on breaker G and turn key to unlock. Key A-1 is now trapped. Breaker G can now be closed and load M has been transferred from breaker A to generator.

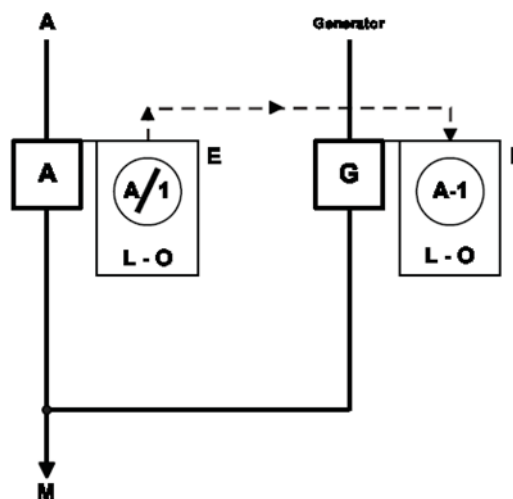

Type KC40 Isolation Interlock



DRAWING

Dimensions: in inches

SD Series Type KC40

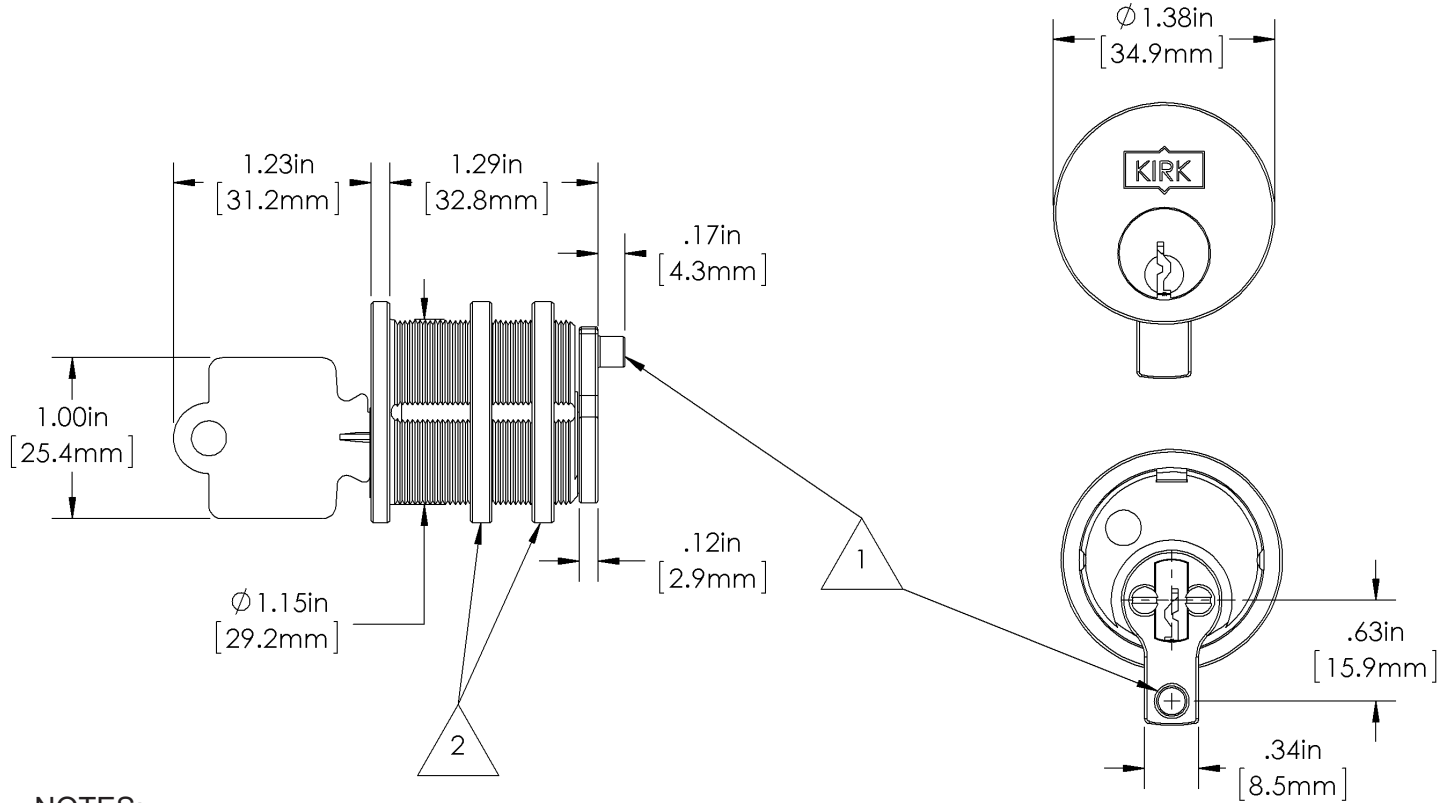

NOTES:

- 1) 3/16" (4.76mm) diameter pin.
- 2) Two locking nuts provided.
- 3) All dimensions on this drawing are reference dimensions.

ORDER INFORMATION

	1	2	3	4	5	6	7	8	9	10
Part number	K	C	4	0	-	-	-	1	0	

10	Stamp Key Interchange max. 5 alphanumeric characters	- = No S = Yes
----	---	-------------------

CONTACT INFORMATION

The Kirk Key Interlock Company LLC

9048 Meridian Circle NW North Canton, OH 44720, USA

Toll Free: +1 800-438-2442 O: +1 234-209-9301 F: +1 330-497-4400

Quotes & Inquiries sales@kirkkey.com PO Submission & Orders orders@kirkkey.com