

BEMF Motion Sensing Interlock

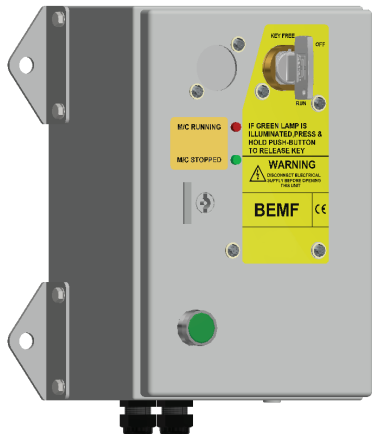

Part of the
Sentric Group



The BEMF Motor sensing Interlock is designed to control access to rotating machinery. The BEMF unit relies on the measurement of the electromotive force generated by the windings of an electric motor. Only when the motor has stopped will the BEMF drop to zero and allow the release of the interlock key. The unit is used for connection to AC and DC motors including DC braking systems. The BEMF has been designed to provide the highest level of safety when installed as part of an access control system for dangerous machinery.

OPERATION

The BEMF is typically used for machine isolation in applications in order to protect the hazardous area from access while power is on.

BEMF Switch Disconnecter

- 1 Power is on, key is trapped. Red LED is illuminated.



While the power is on and a motor is running, the key is trapped in the BEMF motor sensing interlock. A red LED is illuminated.

- 2 Turn the key to OFF position. At zero movement detection a signal is sent to the BEMF to energise the solenoid. A green LED is illuminated. Release the key by pushing the green button.

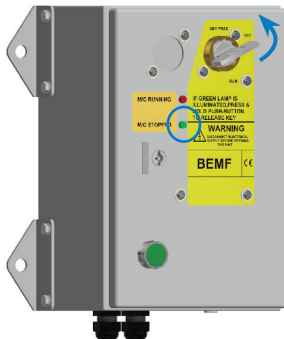

Turn the key to OFF position to switch the power off. A movement detector gives a signal to the BEMF unit once zero movement has been detected. This will illuminate a green LED. The key may now be released by pushing the green button. This key is then taken to unlock the access lock on the motor unit.

- 3 Key is released, power is off and the motor stands still.

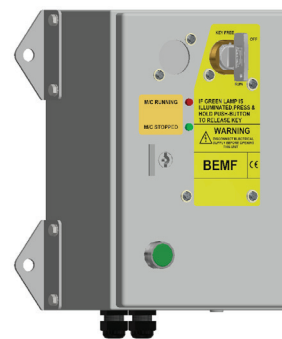

The motor stands still and power is off until the key is replaced in the BEMF motor sensing unit.

USAGE

The BEMF motor sensing unit is designed to be part of a safety system and is used to switch off the power and detect zero motor movements before releasing a key which is then used to gain access to a hazardous area via an access interlock such as the DM.

 The BEMF motor sensing unit is not designed for security purposes.

INSTALLATION

The BEMF motor sensing unit should be mounted to a surface using suitable fasteners (please refer to drawing on page 4 for more details). The lock face should be sealed to the panel for ingress protection.

Cables should be connected to the switch in accordance with the applicable wiring diagrams. Ensure that the unit is bonded for earth continuity (please refer to drawing on page 4 for more installation details).

 **IMPORTANT:** The interlock should be mounted using anti-tamper fasteners to prevent unauthorised removal.

 The BEMF range of motor sensing units must be installed by a competent and qualified person who has read and understood these instructions. Please retain this document in your technical file.

 The manufacturer should be consulted when use in a corrosive environment is planned.

MAINTENANCE

Periodic visual checks should be carried out by the site manager / safety officer.

Do not lubricate lock barrel with oil or grease, use dry powder graphite if necessary.

In case of defects being detected please contact KIRK Key Interlock. Please see contact section for contact details.

 The interlock must be inspected every 6 months. Safety checks should include ensuring the keys can only be removed in the correct safety operating conditions (see page 1).

BEMF Motion Sensing Interlock



Part of the
Sentric Group

TECHNICAL DATA

Temperature	Minimum: 23°F
	Maximum: 131°F
Type of mounting	Surface mount using suitable fasteners (please refer to drawing on page 4 for more details)
Attachment	Inches: 9.45"(H) x 5.51"(W)
Weight	11.lbs
Material	Brass or Stainless steel lock portions, powder coated mild steel enclosure
Cable Size	M20 Gland x 2
IP Rating	IP65, NEMA 4 enclosure
Standards	Standstill detection components to UL (US, Canada)
Contact Rating	Continuous, unattended, remote
Use	Motor switch, circuit-breaker or control switch
Voltage	24 VDC and 240 VAC, 120 VAC
Max motor voltage	600 V
Max power consumption	20 VA / 18 W
Operation	Suitable for 1,000,000
Shock & vibration	In accordance with BS EN 50155 & IEC 61373
PL rating	PLe
B10d	2,000,000

APPLICATION

The BEMF is a safety component designed to operate as part of an integrated safety system. The BEMF controls access to hazardous areas with rotary machinery.

When the electric motor is running, the key of the BEMF interlock cannot be removed, hence preventing access to the hazardous area. To gain access to the area, the electrical supply to the machine must be switched off by turning the key to OFF position. This changes the switches of the electrical supply to the machine to a safe condition. A movement sensing detector sends a signal to the BEMF unit once a zero movement of the motor has been stated. A green LED illuminates. By pushing the green button, the key can now be removed and taken by the operator to the DM access interlock.

The guard may only be opened when the electrical supply has been switched into a safe condition. The machine cannot be restarted until the door is closed and the key is removed and returned to the BEMF motor sensing unit.

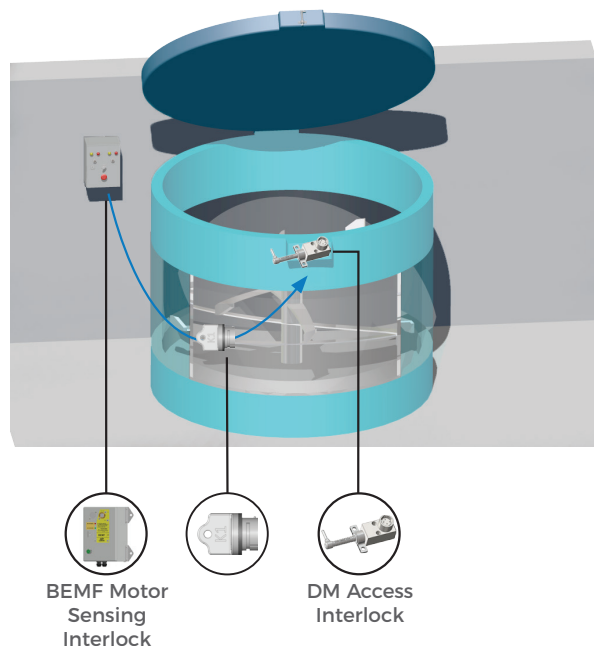

BEMF Motion Sensing Interlock



Part of the
Sentric Group

DRAWING

Dimensions: in inches

BEMF

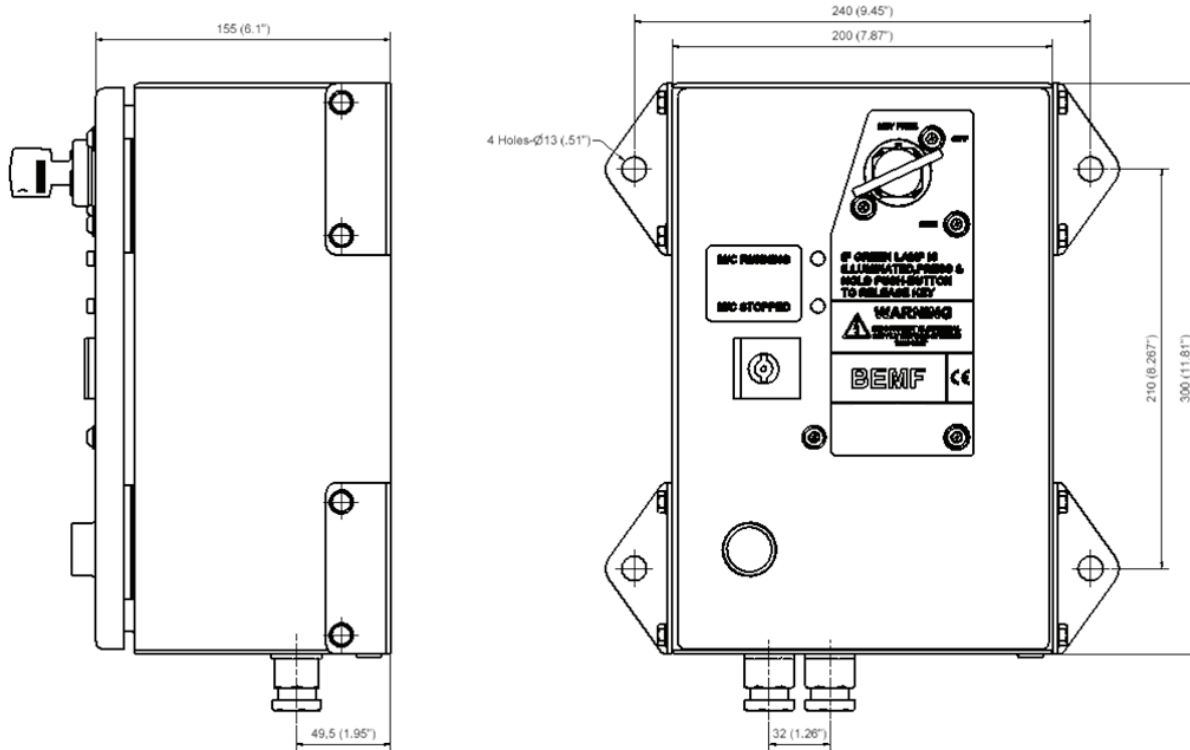

WIRING DIAGRAM

Dimensions: in inches

3 Phase Motor With Star Delta Starting

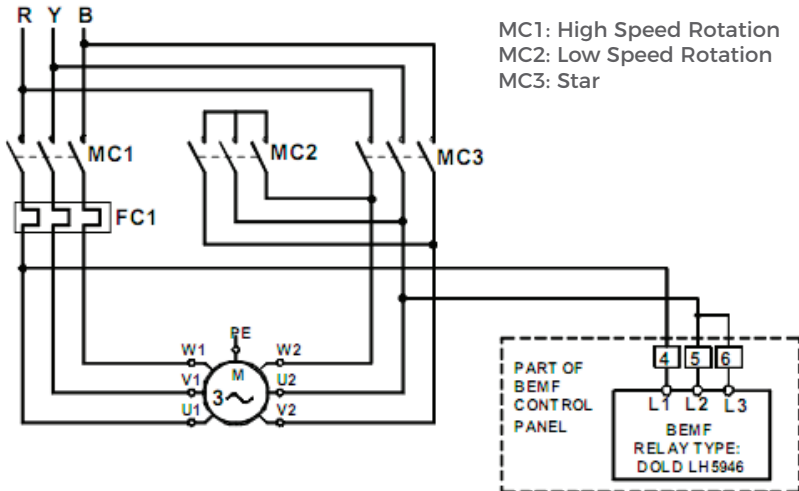

Motors With Switched Winding

Motors with star delta starting or motors with switched windings must be connected the same as a single phase motor as shown opposite in order to avoid interruption in the input circuit.

Otherwise the unit will see this as a broken wire.

For motors with reversing circuit and multi speed motors please follow the same procedure. Whenever 3 phase connections are switched over, if interruption is greater than 2 sec, the BEMF unit will detect broken wire condition. In order not to store this failure the unit should be set as auto reset (i.e. link terminal X2 & X3 of BEMF relay)

3 Phase Motor With Variable Speed Drive

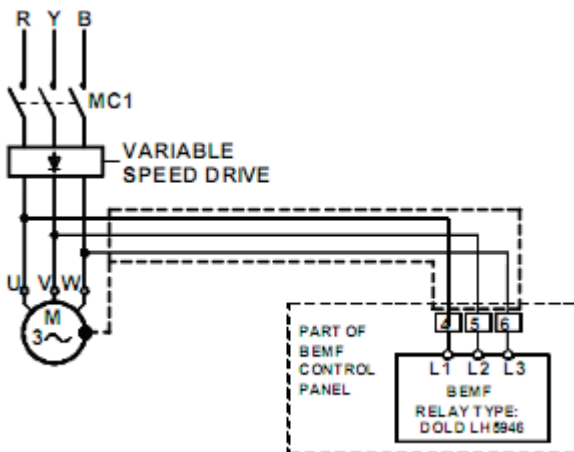

Operation With Electronic Motor Controller

When there are inverters in the installation, it is recommended to use screened cables to the motors. The screen can be connected to the motor housing.

BEMF Motion Sensing Interlock



Part of the
Sentric Group

WIRING DIAGRAM

Dimensions: in inches

3 Phase Motor Direct on Line (DOL)

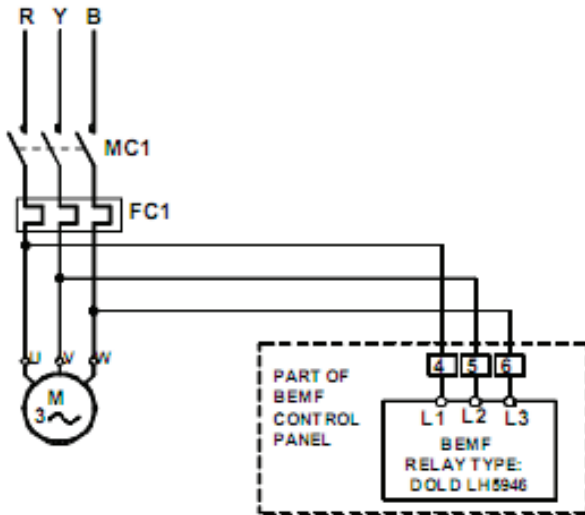

AC Single Phase or DC Motor

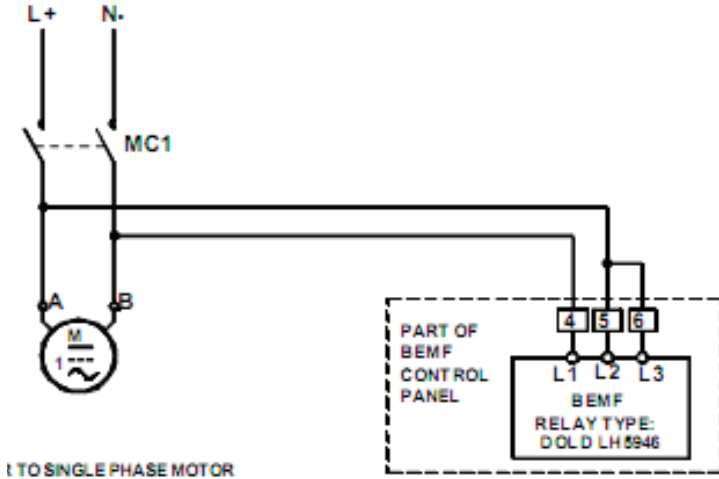

Operation With DC Motors

The connection is made similar to single phase motor. DC motor generate a remanence voltage during run down and unit will detect this as broken wire. In order not to store this failure the unit should be set as auto reset (i.e. link terminal X2 & X3 of BEMF relay)

BEMF Motion Sensing Interlock



Part of the
Sentric Group

ORDER INFORMATION

	1	2	3	4	5	6	7	8	9	10	11	12
BEMF Part number	B	E	M	F	-	K	H	D	-	F	-	

12	Voltage and Current Options	24D = 24 Volts DC, 110A = 110 Volts AC, 240A = 240 Volts AC
----	-----------------------------	---

ACCESSORIES



LOTO Flip Cover Part number	5	0	3	0	6	6	0	0	1
-----------------------------	---	---	---	---	---	---	---	---	---

CONTACT INFORMATION

The Kirk Key Interlock Company LLC

9048 Meridian Circle NW North Canton, OH 44720, USA

Toll Free: +1 800-438-2442 | O: +1 234-209-9301 | F: +1 330-497-4400

Quotes & Inquiries: sales@kirkkey.com | PO Submission & Orders: orders@kirkkey.com