

TYPE DS Access Interlock

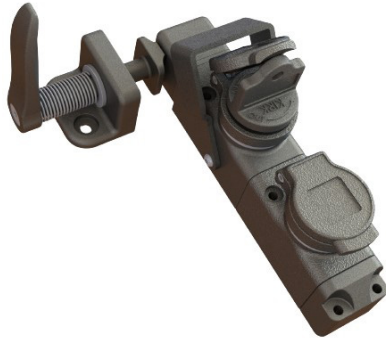

Part of the
Sentric Group



KIRK Type DS access interlocks provide a physical barrier to either partial or full body access points until risk of hazardous energy or moving equipment has been mitigated. Mounted vertically, its slim design can be easily incorporated into machine guarding gates and access points.

The Type DS interlock is a modular interlock that has at least two parts; a main body with one cylinder and a latch bolt. When the latch bolt is separated from the main body, the key(s) is trapped in the lock.

When the door on which the interlock is mounted, is properly closed, the latch bolt can be inserted into the main body and the key(s) can be turned and released. The modular capability of the Type DS provides the flexibility to add multiple cylinders based on the safety application needs. A multiple cylinder Type DS also offers a forced key removal feature which ensures that when the door is opened, the “personnel” key is released and can be put in the pocket of the maintenance person, ensuring that the door cannot be closed and locked while the personnel key is on the person.

OPERATION

KIRK Type DS interlocks are mechanically operated and suitable for access applications in which hazardous energy or moving equipment is present.

1

Key is released, latch bolt is engaged, ensuring access point is locked closed.

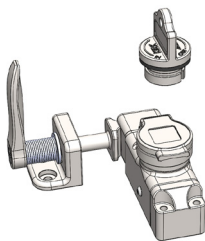

2

Insert and turn key, which will disengage latch bolt and trap key.

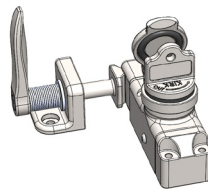

3

Latch bolt is disengaged, access point is open, and key is trapped.

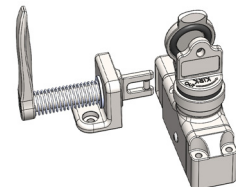

For multiple cylinder interlocks, all missing keys must be inserted and turned before any trapped keys can be released.

TYPE DS Access Interlock



Part of the
Sentric Group

USAGE

KIRK Type DS access interlocks should be used to allow safe access into potential hazardous areas. KIRK Type DS access interlocks can be used for partial or full body access points. For full body access, a multiple cylinder interlock is recommended to ensure a personnel key can be released and kept on the person(s) performing maintenance.

 KIRK Type DS interlocks should be utilized in situations where the door and door-frame are ill-fitting, and a degree of latitude is required.

No hazardous substances were used in the manufacturing of the product. The product can be disposed of in standard waste receptacles.

INSTALLATION

Bolt the Type DS latch bolt to the door or door frame ensuring that when the door/gate is closed, the latch bolt engages properly with the Type DS lock body.

The Type DS access lock is part of our HD series (stainless steel) interlocks and are not sold with keys. Keys must be ordered separately and may be required during the installation process.

 For all interlock systems to maintain system integrity, additional keys must be removed from the system and destroyed or retained by a responsible person. There should only be enough keys to operate the interlock system sequentially. Kirk Key Interlock Company will not be responsible for extra keys left in the interlock system.

 All interlocks and interlock systems must be installed by a competent and qualified person who has read and understood these instructions. Please retain this document in your technical files.

MAINTENANCE

Kirk key interlocks should be periodically lubricated with a small amount of dry powder graphite. DO NOT use oil or grease of any type as these will collect dirt and impede the proper operation of the lock cylinder.

HD SERIES: Apply a small amount of graphite behind the inner turn shaft. Insert and turn the key a few times in order to distribute the graphite below the lock cylinder.

KIRK offers a Graphite Lubrication kit (part# GL-1) complete with instructions for use.

TYPE DS Access Interlock



Part of the
Sentric Group

TECHNICAL DATA

Type DS	KIRK HD Series
Interlock Housing	Stainless Steel
Cylinder Housing	Stainless Steel
Plug/Inner Turn Shaft	Stainless Steel
Key Material	Stainless Steel
Key Style	Dowel Pin
Latch Bolt	Stainless Steel
Type of Mounting	Main body is vertically mounted to the door frame and the latch bolt is mounted to the door using suitable fasteners. Refer to drawing for details.
Temperature Ratings	-58F to +158F
Weight	4.085 lbs
Operation Cycles	Suitable for +1 milion cycles
B10d	B10d - 1 million
Retention Force	3.4KN
Shock & Vibration	In accordance with BS EN 61373:2010 (Category 1 Class B) BS EN 50155:2017 Section 13.4.11
PL Rating	PLd

* Weight based on product with 1 cylinder, no key, accessories, or mounting hardware.

TYPE DS Access Interlock



Part of the
Sentric Group

APPLICATION WRITE UP

KIRK Type DS interlocks are mechanically operated and suitable for access applications in which hazardous energy or moving equipment is present. The interlock application is to prevent the opening of guard B when power is on. Initial system status: Power is on. Guard B is locked closed and switch is in the closed position. Key A-1 is trapped in the bolt interlock on the switch.

To gain access and begin maintenance on moving equipment, open switch and turn key A-1 in bolt interlock on switch. Key A-1 is now free and switch is locked open. Insert Key A-1 into Type DS L-C (locked closed) interlock on Guard B and turn and unlock. Guard B is now open and Key A-1 is now trapped in Type DS.

If this is full body access a multiple cylinder Type DS is recommended. This allows for Key A-2 to be released and held with the person performing maintenance.

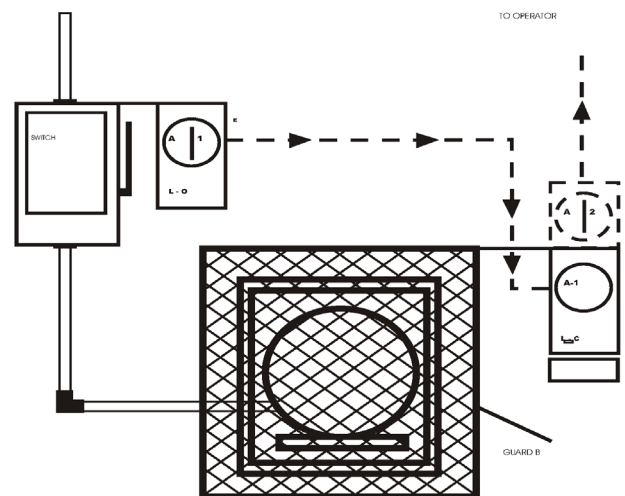

TYPE DS Access Interlock



Part of the
Sentric Group

DRAWING

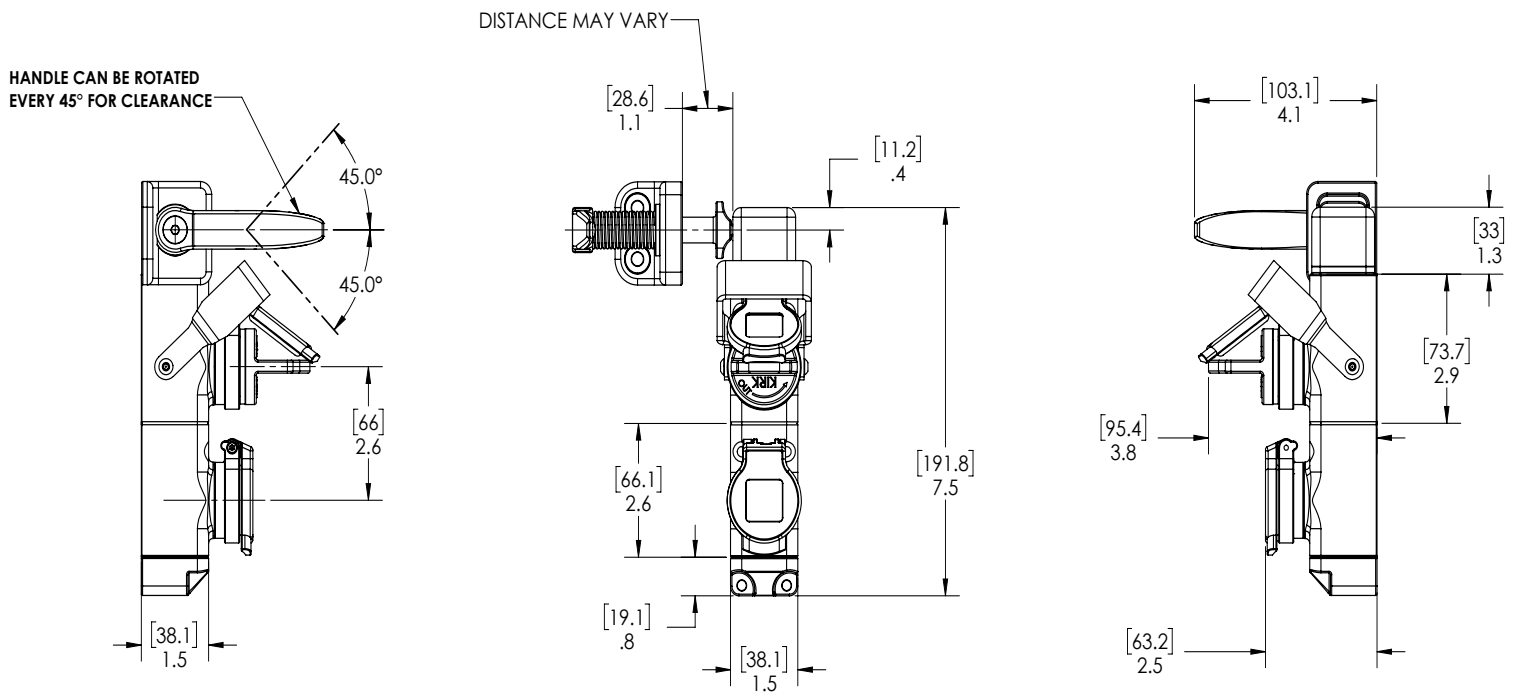

TYPE DS Access Interlock



Part of the
Sentric Group

ORDER INFORMATION

1	2	3	4	5	6	7	8	9	10	11	12	13	14
S	D	S	-	K	K	I			-	-		-	

1,2,3	Lock Type	Type DS Access Lock											
5,6,7	Cylinder Type	KKI= KIRK											
8,9	Cylinder(s)	1 0	= E 1 CYL	Key Free/Door Locked	4 0	= EEEE 4 CYL	Keys Free/Door Locked						
		2 0	= EE 2 CYL	Keys Free/Door Locked	4 1	= WEEE 4 CYL	W-Key Trapped/Door Locked						
		2 1	= WE 2 CYL	W-Key Trapped/Door Locked	4 2	= WWEE 4 CYL	W-Keys Trapped/Door Locked						
		3 0	= EEE 3 CYL	Keys Free/Door Locked	4 3	= WWWE 4 CYL	W-Keys Trapped/Door Locked						
		3 1	= WEE 3 CYL	W-Key Trapped/Door Locked	W Key positions begin at latch bolt. For more than 4 cylinders, please consult sales.								
		3 2	= WWE 3 CYL	W-Keys Trapped/Door Locked									
12	Access Head Position	L = Left R = Right											
14	Stamp Key Interchange	- = No S = Yes											

Protective Covers are standard offering on all Type DS access locks

Tamperproof Hardware is shipped standard with all Type DS access locks

Forced Key Removable Feature:

- Forced key removable feature standard on multiple cylinder Type DS configured with W-Key(s) trapped when door is locked.
- Not available on multiple cylinder Type DS configured with key(s) free when door is locked.
- Not available on single cylinder Type DS

CONTACT INFORMATION

The Kirk Key Interlock Company LLC

9048 Meridian Circle NW North Canton, OH 44720, USA

Toll Free: +1 800-438-2442 O: +1 234-209-9301 F: +1 330-497-4400

Quotes & Inquiries sales@kirkkey.com PO Submission & Orders orders@kirkkey.com

